

Do not use the Cup Holder to hold hot liquids (e.g. coffee), even in enclosed or lidded containers. Placing hot liquids in the holder could result in spills and burn injuries to you or your child.

Only use appropriate containers that will slot all the way to the bottom of the holder, with no more than half protruding above the top of the Cup Holder.

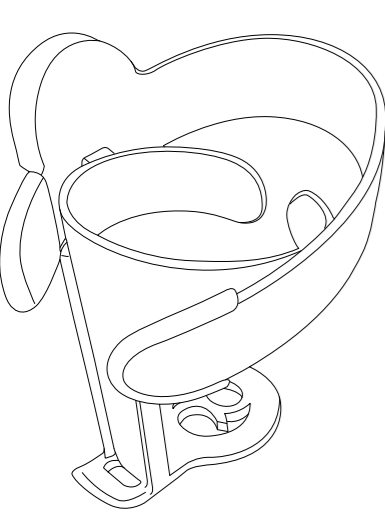

Do not use the Cup Holder to hold hot liquids (e.g. coffee), even in enclosed or lidded containers. Placing hot liquids in the holder could result in spills and burn injuries to you or your child.

Only use appropriate containers that will slot all the way to the bottom of the holder, with no more than half protruding above the top of the Cup Holder.

2-IN-1 CUP HOLDER PORTE-GOBELETS 2 EN 1

Do not use the Cup Holder to hold hot liquids (e.g. coffee), even in enclosed or lidded containers. Placing hot liquids in the holder could result in spills and burn injuries to you or your child.

Only use appropriate containers that will slot all the way to the bottom of the holder, with no more than half protruding above the top of the Cup Holder.

CYBEX GmbH
Riedingerstraße 18
95448 Bayreuth
Germany
+49 (0) 921-78 511 - 0
info@cybex-online.com

WARNING!	EN
<ul style="list-style-type: none">Do not use the Cup Holder to hold hot liquids (e.g. coffee), even in enclosed or lidded containers. Placing hot liquids in the holder could result in spills and burn injuries to you or your child. Only use appropriate containers that will slot all the way to the bottom of the holder, with no more than half protruding above the top of the Cup Holder.	

BELANGRIJK!	NL
<ul style="list-style-type: none">Gebruik de cuphouder niet voor hete vloeistoffen (bijv. koffie), dit kan leiden tot brandwonden voor uw kind. Gebruik geschikte bekert, die niet helemaal wegzakken tot op de bodem van de houder, en waarij er niet meer dan helft van de beker boven de houder uitsteekt.	

ПРЕДУПРЕЖДЕНИЕ!	BG
<ul style="list-style-type: none">Не поставяйте вътре чаши с горещи напитки (кафе и др.), дори да са затворени или с капак. Евантуално разливане на течността може да изгори кожата на детето. Ползвайте само подходящи чаши, които ще стигат до дъното на поставката и на които не повече от половината ще се подава от нея. 	

תורהא!	HE
<ul style="list-style-type: none">אין להשתמש במחזיק כוס להחזיק נוזלים חמים (למשל קפה), אפילו במיכלים סגורים. הצבת נוזלים חמים במחזיק כוס עלול לגרום לנזול ששפך כויות או פציעות לך או לילדך. יש להשתמש אך ורק במיכלים מתאימים הנכנסים כל הדרך אל החלק התחתון של מחזיק הכוס. עם לא יותר מחצי מיליו נוזלים מעל החלק העליון של מחזיק הכוס.	

UYARI!	TR
<ul style="list-style-type: none">Bardak tutucuyu sıcak içecekler (kahve vb) için, kapaklı, kapalı bardaklarda dahi olsa, kullanmayınız Dökülmesi ve sıçraması durumunda bebeğinizin yanmasına sebep olabilirler. Yalnızca tutucuya tam oturan kaplar için kullanın, Bardak Tutucunun üstünde kalan veya yanısı dışında kalan kaplar için kullanmayın.	

警告!	ZH TW
<ul style="list-style-type: none">請勿使用杯架放置熱的飲品(比如：咖啡),即使是 有杯蓋或是裝在容器內。放置熱的飲品在杯架上可能導致熱飲灑出或是燙傷您或您的孩童。 請使用適當的容器,使其可以完整的插入杯架底部並且不突出高於半個杯架。	

WARNING!	US/CAN-EN
<ul style="list-style-type: none">Do not use the Cup Holder to hold hot liquids (e.g. coffee), even in enclosed or lidded containers. Placing hot liquids in the holder could result in spills and burn injuries to you or your child. Only use appropriate containers that will slot all the way to the bottom of the holder, with no more than half protruding above the top of the Cup Holder.	

WARNUNG!	DE
<ul style="list-style-type: none">Verwenden Sie den Getränkehalter nicht für heiße Flüssigkeiten (z.B. Kaffee), auch wenn sich diese in geschlossenen oder mit Deckel versehenen Behältern befinden. Heiße Flüssigkeiten im Getränkehalter zu bewahren kann bei Verschütten zu Verbrennungen bei Ihnen und Ihrem Kind führen. Verwenden Sie nur geeignete Trinkbehälter, die bis zum Boden des Getränkehalters reichen und nicht mehr als die Hälfte über den oberen Rand des Getränkehalters hinaus überstehen.	

OSTRZEZENIA!	PL
<ul style="list-style-type: none">Nie wstawiaj do uchwyty na kubek gorących napojów (np. kawy), ponieważ mogą być one przyczyną poparzeń. Zwróć uwagę na rozmiar pojemnika: po wstawieniu do uchwyty pojemnik powinien opierać się o spód uchwyty i nie powinien z niego wystawać więcej niż połowa wysokości.	

FIGYELMEZTETES!	HU
<ul style="list-style-type: none">Ne használja a pohártartó forró italokhoz (pl. kávéhoz), mert azzal égési sérülést okozhat magának vagy gyermekekének. Csak olyan poharat használjon, amely teljesen illeszkedik a tartóhoz, leér a tartó aljáig, és a pohártartóból max. csak a fele áll ki.	

HOIATUS!	ET
<ul style="list-style-type: none">Ärge kasutage topsihoidjat kuumade jookide ho-idmiseks(nt. kohvi), isegi mitte kaanega või su-letud topse Kuumade jookide ümberminek võib tekitada vigastusi nii Teile kui Teie lapsele. Kasutage ainult sobivaid joogitopse, mis mahuvad korralikult hoidja põhja ning mis ei ole üle poole hoidjast väljas.	

ΠΡΟΕΙΔΟΠΟΙΗΣΗ!	EL
<ul style="list-style-type: none">Μην χρησιμοποιείτε την ποτηροθήκη για ζεστά υγρά (πχ. καφέ), ακόμα και σε κλειστές συσκευασίες. Η υποθέτηση ζεστών υγρών στην ποτηροθήκη μπορεί να έχει ως αποτέλεσμα να λεριαστείτε ή να καείτε εσείς και το παιδί σας. Χρησιμοποιείτε μόνο δοχεία που θα χωράνε ολόκληρα στο βάθος της θήκης, χωρίς να προεξέχουν περισσότερο από τη μέση της ποτηροθήκης.	

警告!	JA
<ul style="list-style-type: none">コーヒーなど高温の液体は、たとえ蓋つきの容器に入っけていても、カップホルダーに入れないでください。容器から液体がこぼれて、お子さまやお客様が火傷をするおそれがあります。 カップホルダーに入れる容器は、カップホルダーの底まで正しく入れた状態で、カップホルダーの上端から、その容器の半分以上が出ない適切な大きさのものとしてください。容器が不安定だと液体がこぼれて、お子さまやお客様が火傷やケガをするおそれがあります。	

MISE EN GARDE!	US/CAN-FR
<ul style="list-style-type: none">N'utilisez pas le porte-gobelet avec des liquides chauds (café, p. ex.) au risque d'exposer votre enfant à des brûlures. N'utilisez que des récipients appropriés qui s'emboîtent parfaitement jusqu'au fond du porte-gobelet, de sorte que la moitié du récipient maximum dépasse du haut du porte-gobelet.	

AVERTISSEMENTS!	FR
<ul style="list-style-type: none">N'utilisez pas le porte-gobelet avec des liquides chauds (café, p. ex.) au risque d'exposer votre enfant à des brûlures. N'utilisez que des récipients appropriés qui s'emboîtent parfaitement jusqu'au fond du porte-gobelet, de sorte que la moitié du récipient maximum dépasse du haut du porte-gobelet.	

VAROVÁNÍ!	CS
<ul style="list-style-type: none">Nepoužívejte držák šálku na horké kapaliny (například na kávu), aby nedošlo k popálení vás či vašeho dítěte. Vždy používejte pouze vhodné nádoby, které zapadnou až na dno držáku a u kterých bude nad okraj držáku vyčnívat méně než jedna polovina jejich výšky.	

VARNING!	SV
<ul style="list-style-type: none">Använd inte mugghållaren till varma vätskor (t.ex. kaffe) då detta kan orsaka brännskador på dig eller ditt barn. Använd lämpliga behållare som glider hela vägen ner till hållarens botten, utan att mer än hälften sticker upp ovanför mugghållaren.	

BRĪDINĀJUMS!	LV
<ul style="list-style-type: none">Neizmantojiet glāžu turētāju karstu dzērienu (piem. kafijas) turēšanai, pat ja trauks ir noslēgts. Karsts šķidrums atrodoties turētājā var izšļakstīties un radīt apdegumus jums vai jūsu bērnam. Izmantojiet tikai tādus traukus, kurus ieliekot turētājā tie saskaras ar pamatni, un virs turētāja neatrodas vairāk kā puse no kopējā trauka garuma.	

AVERTIZARE!	RO
<ul style="list-style-type: none">Nu utilizați suportul pentru pahare să dețină lichide fierbinți (de exemplu, cafea), chiar și în recipiente închise sau containere închise Plasarea lichidelor fierbinți în suportul ar putea duce la scurgeri și produce arsuri si leziuni pentru tine sau copilul tau. Utilizare numai recipiente adecvate care vor intra in partea de jos a suportului, cu mai mult de jumătate lui si din înaltimea pe partea superioare pentru destinatאר suportului.	

경고!	KO
<ul style="list-style-type: none">뚜껑이 있거나 잘 밀봉되어 있는 컵이라도, 뜨거운 액체(예, 커피)가 들어 있는 컵을 이 컵홀더에 놓아 두지 마십시오. 이 홀더에 있는 뜨거운 액체가 쏟아져 고객님이나 고객님의 아이가 화상을 입을 수 있습니다. 이 컵홀더의 바닥까지 완전히 닿을 정도의 적절한 사이즈의 용기만을 사용해 주시고, 컵홀더의 밑 부분 위쪽으로 반이상 튀어오르는 용기는 사용하지 마십시오.	

¡ADVERTENCIAS!	ES
<ul style="list-style-type: none">No use el portavasos para líquidos calientes (como el café), ya que podría quemarse o producir quemaduras a su hijo. Utilice únicamente vasos u otros contenedores que se puedan introducir en el portavasos sin que sobresalga más de la mitad por encima del mismo.	

VAROVANIE!	SK
<ul style="list-style-type: none">Držiak na nápoje nepoužívajte za skladovanie horúcich tekutín (napr. kávy), pretože by to mohlo spôsobiť popáleniey vám alebo vášmu dieťaťu. Používajte iba vhodné nádoby, ktoré prejdú otvorom až naspodok držiaka tak, aby z neho nevyčnievala viac ako polovica nádoby. 	

ADVARSLER!	NO
<ul style="list-style-type: none">Ikke bruk kopholderen for varme væsker (f.eks. kaffe), da dette kan føre til brannskader på deg eller barnet ditt. Bruk kun passende beholdere som passer helt ned i bunnen av holderen, uten at mer enn halvparten sticker over toppen av kopholderen.	

DĖMESIO!	LT
<ul style="list-style-type: none">Nenaudokite puodelio laikiklio laikyti karšties gėrimams (pvz. kavos), net jei gėrimas yra uždarytame indelyje. Įstatant karštus gėrimus į puodelio laikiklij yra tikimybė nusiplyikyti jums ar jūsų vaikui. Naudokite tik tinkamą skysčio talpą, kuri tilptų į konteinerį taip, kad dugnas pasiektų laikiklio pagrindą, o pilnai įdėjus, indo matytųsi ne daugiau nei pusė.	

إتاري ذحت	AR
<ul style="list-style-type: none">لا تستخدم حامل الكأس لحمل السوائل الساخنة (مثل القهوة) حتى لو كانت في كاسات مغلقة. وضع السوائل الساخنة في حامل الكأس يمكن أن يؤدي إلى تسرب السوائل وإصابات حرق لك أو لطفلك. لا تستخدم سوى كاسات مناسبة والتي من شأنها الدخول على طول الطريق إلى أسفل حامل الكأس، مع عدم وجود أكثر من نصف الكأس فوق الجزء العلوي من حامل كأس.	

UPOZORENJE!	SR
<ul style="list-style-type: none">Nemojte koristiti držač za čaše za vruće napitke (npr. kafa), čak i ako su u zatvorenim, poklopljenim posudama. Prilikom postavljanja vrućih napitaka u držač može da dođe do prospanja, pa Vaše dete može da se opeče. Koristite samo odgovarajuće posude koje uležu u držač skroz do dna, da ne viri više od polovine posude iznad držača.	

AVISOS!!	PT
<ul style="list-style-type: none">Não use o suporte de copo para líquidos quentes (por ex. café) pois pode causar queimaduras a si ou à sua criança. Use apenas recipientes adequados que se encaixem até ao fundo do suporte, com não mais que metade do recipiente saliente acima do suporte de copo.	

OPOZORILA!	SL
<ul style="list-style-type: none">Držala za skodelice ne uporabljajte za vroče tekočine (npr. za kavo), saj obstaja nevarnost, da se opečete vi ali vaš otrok. Uporabljajte samo primerne skodelice, ki bodo segale do dna držala in ki ne bodo segale za več kot polovico njihove višine nad rob držala.	

VAROITUKSIA!	FI
<ul style="list-style-type: none">Älä pidä mukinpidikkeessä kuumia juomia (kuten kahvia), jotta et aiheuta palovammoja itsellesi tai lapsellesi. Käytä vain sellaisia astioita, jotka asettuvat sujuvasti pidikkeen pohjaan asti ja joista jää korkeintaan puolet mukinpidikkeen yläpuolelle.	

ВНИМАНИЕ!	RU
<ul style="list-style-type: none">Не ставьте горячие жидкости (например, кофе) в подстаканник, даже в закрытой ёмкости. Горячие напитки в подстаканнике могут вызвать ожоги у вас и вашего ребенка при разлитии. Используйте только подходящие емкости, половина которых будет прикрыта и половина доступна.	

رابطخا!	FA
<ul style="list-style-type: none">حتی در فنجان های در بسته نیز از نگهدارنده فنجان برای مایعات داغ (مانند قهوه و غیره) استفاده نکنید. ریختن مایعات داغ در نگهدارنده منجر به ریختن مایع و سوختگی شما و کودکان می شود. تنها از ظرفی استفاده کنید که به طور کامل در قسمت انتهایی نگهدارنده محکم و جفت می شود و از ظرفی که قسمتی از آن بالاتر و خارج از نگهدارنده قرار می گیرد به هیچ عنوان استفاده نکنید.	

AWAS!	MS
<ul style="list-style-type: none">Jangan gunakan Pemegang Cawan untuk memegang cecair panas (contohnya kopi), walaupun di dalam bekas tertutup atau bertutup. Meletakkan cecair panas dalam pemegang boleh menyebabkan cecair tersebut tumpah dan menyebabkan anda atau anak anda tercedera akibat melecur. Gunakan bekas yang sesuai sahaja yang akan masuk sehingga ke bahagian bawah pemegang, dengan tidak lebih daripada separuh bagiannya berada di bahagian atas Pemegang Cawan.	

AVVERTENZE!	IT
<ul style="list-style-type: none">Non usare il portabicchiere per contenere liquidi molto caldi (ad es., caffè), poiché potrebbero ustionare voi o il bambino. Utilizzare solamente contenitori adatti che si inseriscano fino in fondo al portabicchiere e di cui non sporga più della metà oltre il bordo del portabicchiere.	

UPOZORENJE!	HR
<ul style="list-style-type: none">Nemojte u držaču nositi vruće tekućine (npr. kavu) zbog opće opasnosti od opekline. Koristite samo čaše koje se mogu postaviti u držač tako da dotiču dno i ne vire iz držača za više od pola.	

ADVARSLER!	DA
<ul style="list-style-type: none">Anvend ikke kopholderen til varme væsker (fx kaffe), da dette kan forårsage forbrændinger på dig eller dit barn. Anvend kun passende beholdere, der går hele vejen ned i bunden af holderen, så ikke mere end halvdelen af beholderen rager op over kopholderen.	

УВАГА!	UK
<ul style="list-style-type: none">Не використовуйте підставку для чашки для горячих напоїв, оскільки це може спричинити опіки вашої дитини. Використовуйте тільки чашки відповідного розміру, які чітко підійдуть за розміром підставки.	

警告!	ZH
<ul style="list-style-type: none">請勿使用杯架放置熱的飲品(比如：咖啡),即使是 有杯蓋或是裝在容器內。放置熱的飲品在杯架上可能會導致熱飲灑出或是燙傷您或您的孩童。 請使用適當的容器,使其可以完整的插入杯架底部並且不突出高於半個杯架。	

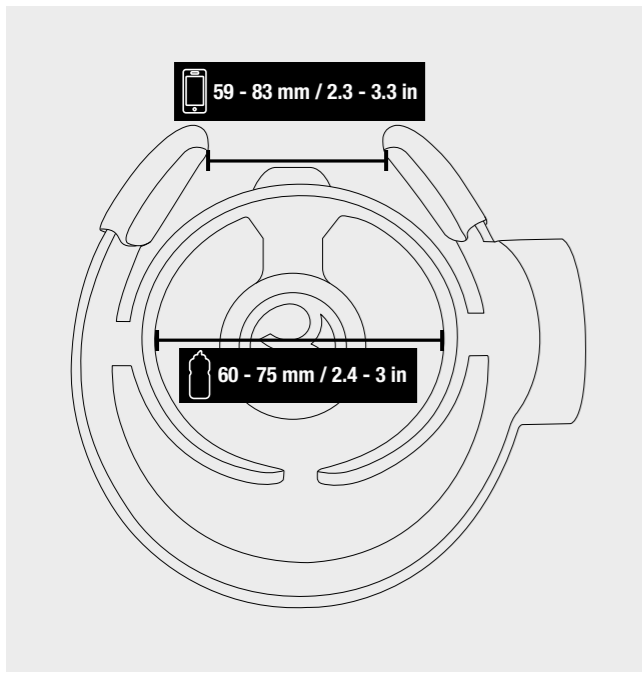

1

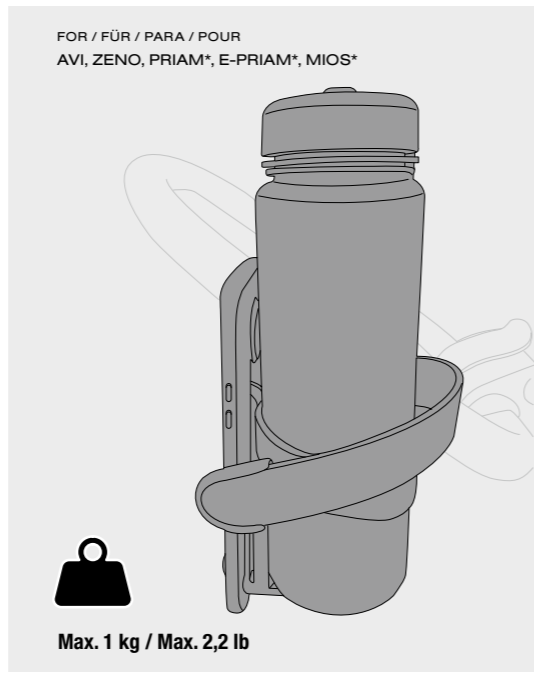

2

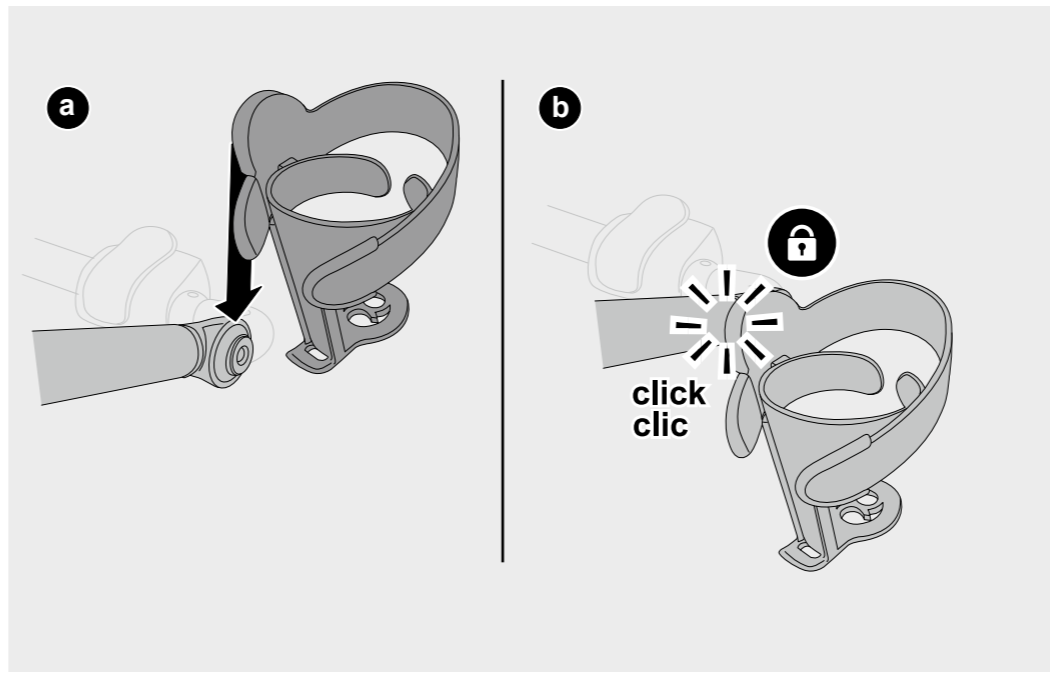

3

*Collection 2022 and following / *Kollektion 2022 und folgende
*Colección 2022 y próximas / *Collection 2022 et +

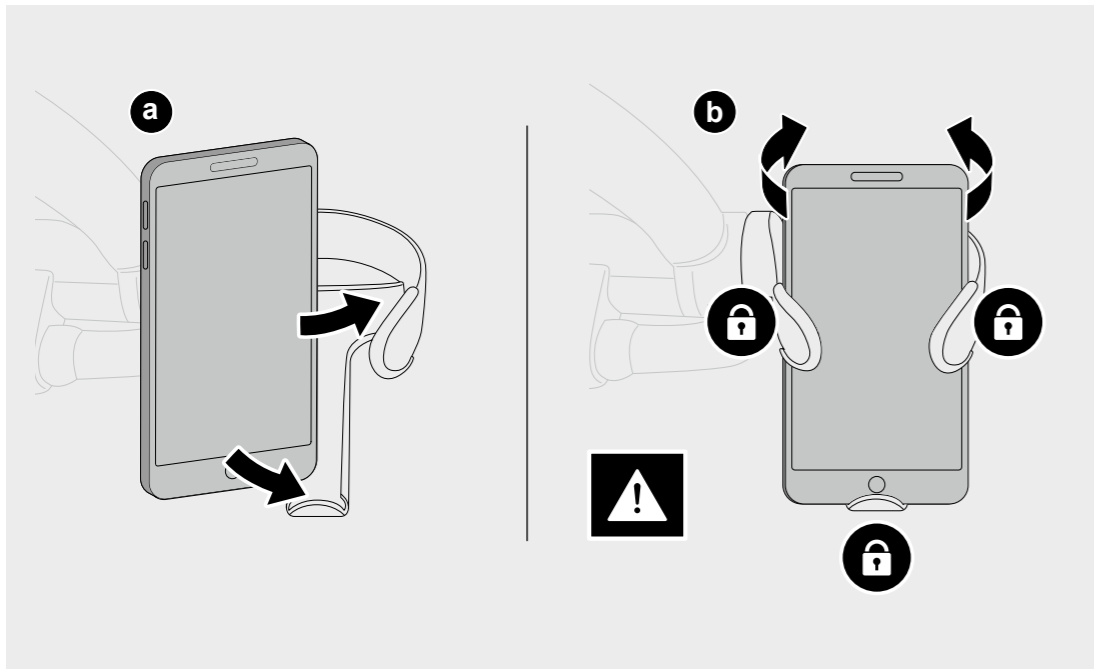

5

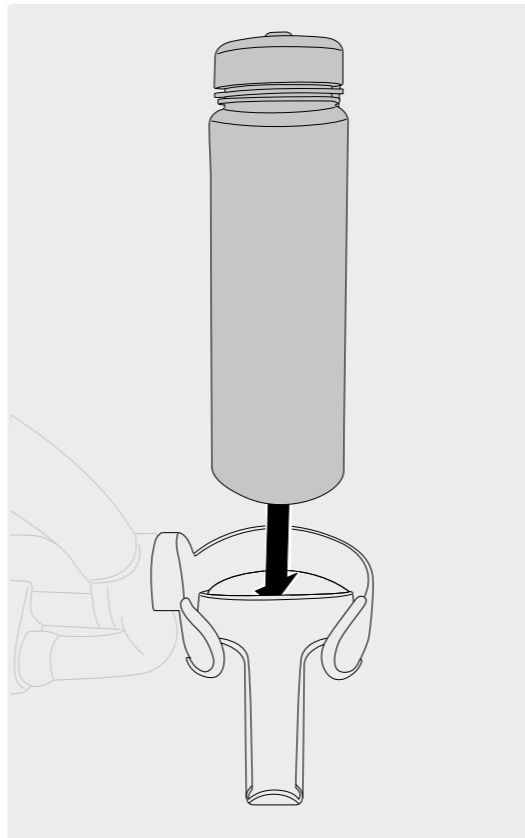

6

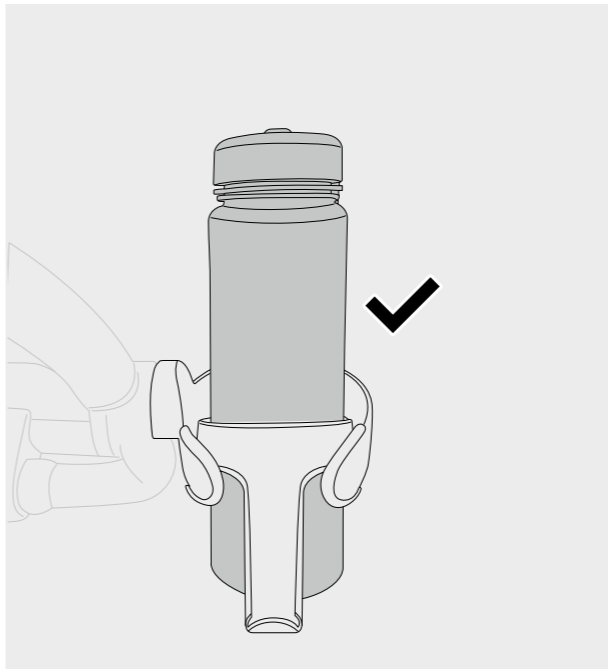

7



8

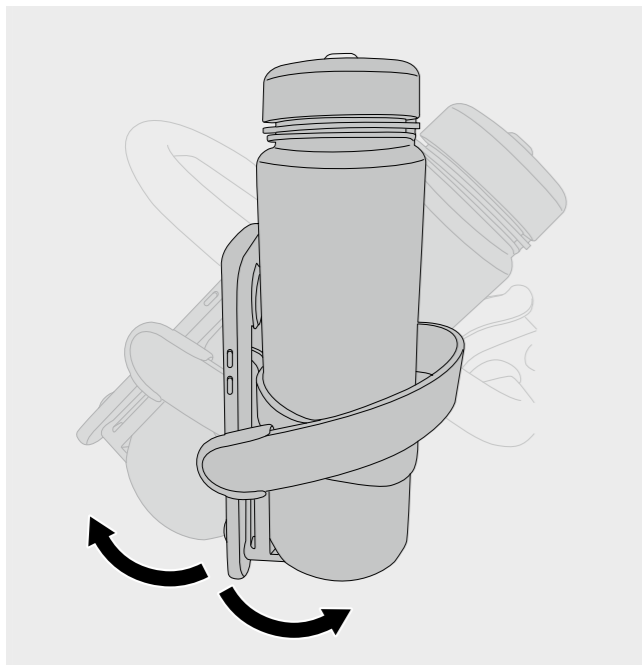

9

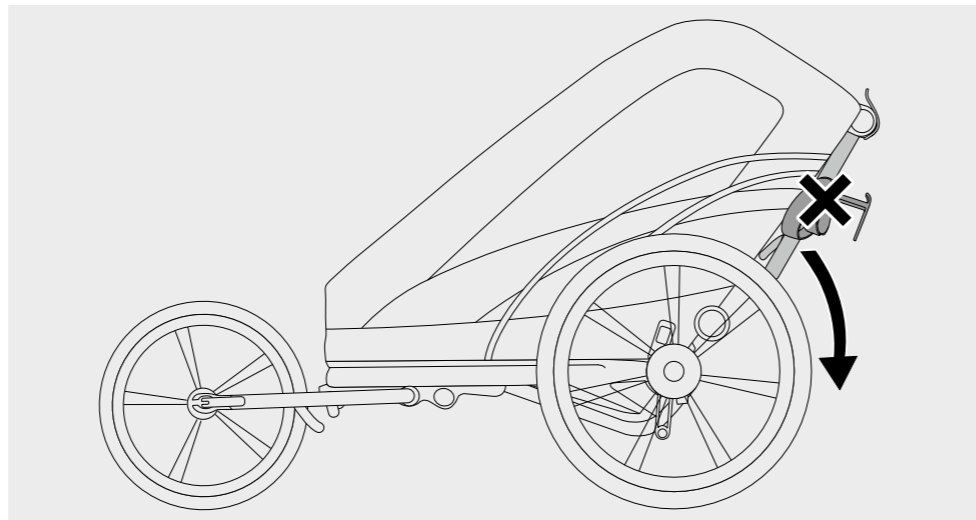

10